

Registrar Bulletin - No. 02

Claims Process - Condominium Common Elements

Issue Date: February 1, 2021

Effective Date: February 1, 2021

(This Bulletin replaces the former Builder Bulletin 42 - Customer Service Standard. It applies to claims made on or after February 1, 2021.)

What This Guideline is All About

This Bulletin sets out what can be described as a customer service standard for warranty claims made in relation to Common Elements for residential condominiums. It addresses the following matters:

- Sets out a process for how condominium corporations must submit statutory warranty claims for Common Elements; and
- Establishes timelines within which builders must respond to and resolve claims; and the role of Tarion in the process.

The Common Elements (CE) Claims Process sets out minimum standards required by Tarion. Builders are encouraged to exceed these standards.

The word “builder” when used in this Bulletin includes both a vendor and a builder as applicable.

Table of Contents

Definitions	2
The Common Elements Claims Process.....	5
Step 1: Making a Common Elements Warranty Claim	6
Step 2: Initial Builder Repair Period	7
Step 3: Condominium Corporation Request for Conciliation	8
Step 4: Pre-Conciliation Repair Period	8

Step 5: Conciliation Process	8
Step 6: Post-Conciliation Repair Period	9
Step 7: Tarion Settles the Claim	9
Appendix A: Exceptions to the CE Claims Process	12
Appendix B: Conciliation Fees.....	15

Note: Vacant land condominiums and common element condominiums do not have Common Elements warranty coverage. See section 15 (c) of the Ontario New Home Warranties Plan Act.

Definitions

In this Bulletin, the following terms have the meanings defined below:

Act

The Act is the Ontario New Home Warranties Plan Act, R.S.O. 1990, c. O.31 and Regulations, as amended.

CE Claims Process

Is the process set out in Part II.1 of Regulation 892 and further described in this Bulletin.

Conciliation

Is a process whereby Tarion determines whether an item listed on a Tarion Common Elements Request for Conciliation Form is covered by a statutory warranty and whether the builder is required to perform work or pay compensation. If work was done by the builder, Tarion will determine if it was adequate to remedy the warranted item. A conciliation may include an inspection of the Common Elements or a desk assessment (if items can be assessed based on paper record, including a review of the Declaration and Description and other relevant documentation).

Please Note

Only items identified in a properly submitted Common Elements Request for Conciliation form will be reviewed during the related conciliation. Items raised for the first time by a condominium corporation during a conciliation will not be addressed at that conciliation. Condominium corporations will be directed to add these new items to their next Common Elements Claim form as applicable.

Chargeable Conciliation

Is a conciliation in which:

1. there are items identified as warranted by Tarion in a Warranty Assessment Report;
2. the builder was not denied reasonable access by the condominium corporation to rectify the problem (see "Reasonable Access For Repair" on p. 7 of this Bulletin); and

3. the builder could have avoided the conciliation by attending to the items raised in the Common Elements Form submitted to Tarion.

Even if only one item is confirmed through the conciliation process by Tarion to be warranted, whether major or minor in nature, the conciliation will be considered chargeable to the builder. See Registrar Bulletin No. 04 – How Chargeability is Determined and Applied (formerly Builder Bulletin 20 – How Chargeability is Determined and Applied).

A conciliation may be deemed “not chargeable”, if one or more of the following exceptions apply to every item determined to be warranted in the Warranty Assessment Report:

1. the builder can demonstrate that the condominium corporation denied reasonable access to repair or resolve the warranted item before the conciliation; or
2. a conciliation is conducted by Tarion because the builder and the condominium corporation disagree about the method or timing of the repair of an item that the builder has previously agreed is warranted, and Tarion supports the builder’s recommendation; or
3. the builder can show:
 - (a) that it has a history of satisfactory after-sales service to the condominium corporation; and
 - (b) by way of a written acknowledgement from the condominium corporation, that the condominium corporation had previously confirmed they were satisfied with the state of the item based on the builder’s repair or that the dispute relating to the item was otherwise resolved by the builder. As a result, the builder was completely satisfied that the item had been resolved and took no further action in respect of the item prior to the conciliation.

In addition to the above exceptions, Tarion maintains sole discretion to consider changing a finding of chargeability where the finding relates to an “Extraordinary Situation” as described in Appendix A to this Bulletin or where Tarion determines that the finding relates to an exceptional circumstance.

Common Elements

Are the Common Elements of a condominium corporation which are eligible for statutory warranties and for greater certainty excludes the Common Elements of a Common Elements condominium corporation or of a Vacant Land condominium corporation as described in s.15(c) of Act.

Condominium Project

Means the lands and interests appurtenant thereto that are described or proposed be described in any description required by the Condominium Act and which include or are proposed to include units to be used as “homes” as defined in the Act.

Declaration & Description

Both are disclosure documents under the Condominium Act. Among other things, they provide a description of the Common Element boundaries and list the ownership proportion allocated by unit.

Performance Audit

Means the performance audit of the Common Elements of the condominium project referred to in s.44 of the Condominium Act.

Performance Audit Tracking Summary

Means the Tarion document used to track the status of Common Elements warranty claims made to Tarion.

Registration Date of the Condominium Project

Is the date of registration of the Declaration and Description of the Condominium Project and is the warranty start date for the common elements.

Submit

Means to deliver Statutory Warranty Forms and other documents in accordance with the Regulations. Acceptable methods of delivery are by hand, courier, facsimile transmission or except during a general interruption of postal service, regular mail or registered mail. In the case of regular mail, delivery is effective on the postmark date as long as Tarion receives it within 10 days of the expiry of the applicable period. Registered mail is effective on the postmark date. Facsimile transmission is effective on the date sent whether or not it is a business day. Delivery by hand or courier is effective on the date Tarion receives it if it is a business day and otherwise on the next business day.

Proof of Submission and Delivery

If there is a dispute concerning delivery, the onus is on the builder to establish when delivery occurred. To avoid confusion, builders are encouraged to use methods of delivery (such as registered mail or courier) which will ensure that the builder will have proof of delivery.

Warranty Assessment Report Is a written report issued by Tarion following a conciliation setting out Tarion's assessment on each item listed on a Common Elements Form, Tarion will set out whether the items are warranted and/or whether Tarion supports the method of repair performed by the builder, as applicable. A Warranty Assessment Report may indicate that further investigation is needed.

Warranty Claim

Means a claim made by a condominium corporation to Tarion regarding a common elements matter of a breach of a builder warranty prescribed by the Act.

Common Element Warranty Claim Form

Is the form required by Tarion to be completed and submitted to Tarion in order for a condominium corporation to make a statutory warranty claim. The Common Elements Forms include:

- First Year Common Elements Claim Form
- Second Year Common Elements Claim Form
- Major Structural Defect Common Elements Claim Form

- Performance Audit prepared in accordance with s.44 of the Condominium Act
- Common Elements Emergency Claim Form

The Common Elements Claims Process

The condominium corporation is considered to be the owner of the Common Elements (CE) of a Condominium Project (Section 15 (a) of the Ontario New Home Warranties Plan Act) and is responsible for making statutory warranty claims to Tarion in respect of the Common Elements. Tarion will not accept CE Warranty Claims submitted by individual condominium unit owners.

The CE Claims Process involves specific steps - steps condominium corporations must take to submit a Warranty Claim; repair periods for builders to perform work on warranted items; and steps Tarion will take to become involved if necessary. The condominium corporation may contact its builder at any time and are encouraged to work with its builder to resolve warranty items. Tarion becomes involved in claims only at specific times as described below. However, Tarion may, at any time, conduct a conciliation if it determines that the parties are not acting reasonably to resolve warranty claims submitted to Tarion. Tarion is also available on an informal basis to provide information to the builder and to the condominium corporation at any time.

The time periods in the CE Claims Process are fixed in the Regulations but they may be adjusted in the following two sets of circumstances. In recognition of difficulties which builders may face in scheduling appointments with condominium corporations and/or performing work in the holiday period between December 24th and January 1st (inclusive) every year, any time period fixed in the CE Claims Process will be extended if any portion of the time period occurs during this holiday period. Time periods which would span, or would start or end during this holiday period will be extended by nine days and all related subsequent time periods will be adjusted so that they remain consecutive.

In addition, where a time period ends on a weekend or holiday, the time period is extended to end on the next business day which is not a holiday (i.e., where the time period to submit a Claim Form ends on a Sunday, the time period will be extended to end on the next Monday where Monday is not a holiday).

Exceptions to the CE Claims Process

Exceptions are certain situations where the CE Claims Process is modified to take into account special circumstances (i.e., Emergencies, Seasonal Items, and Industry/Regional Extraordinary Situations). See Appendix A for a detailed explanation of the Exceptions to the CE Claims Process.

Note that Tarion may in its sole discretion, extend or shorten any times set out in the CE Claims Process (including those described in Appendix A) if it determines that a builder is unable or unwilling to repair or resolve the claim items covered by a warranty or where Tarion determines that the builder is not acting reasonably to resolve the items listed on a warranty claim made to Tarion.

Step 1: Making a Common Elements Warranty Claim

The condominium corporation is entitled to make a warranty claim to Tarion at the times specified in the Regulations and described below.

First Year CE Process

To make a CE warranty claim during the first-year warranty period, a condominium corporation must submit a First Year Common Elements Form or a Performance Audit to Tarion with a Performance Audit Tracking Summary. The Performance Audit Tracking Summary must reference all items included on the First Year Common Elements Form or Performance Audit submitted to Tarion.

The Performance Audit Tracking Summary is a tool designed to track the progress of the items that the condominium corporation has submitted to Tarion as part of its warranty claim. Tarion will require periodic updates (usually every 90 days) from both the condominium corporation and the builder as to the status of each of the items listed in the Performance Audit Tracking Summary. In the event that the parties are not working to repair the items or otherwise resolve them in a reasonable and diligent manner, Tarion will hold a mandatory meeting with the condominium corporation and the builder which may result in Tarion scheduling a conciliation inspection.

If the condominium corporation does not submit a First Year Common Elements Claim Form or Performance Audit as described above by midnight on the first anniversary of the registration date of the Condominium Project, then Tarion will consider no further claims for first year warranty items. A condominium corporation may submit as many First Year Common Elements Claim Forms as required within the first year warranty period.

Second Year CE Process

To make a CE warranty claim during the second-year warranty period, a condominium corporation must submit a Second Year Common Elements Form to Tarion with a Performance Audit Tracking Summary. The Performance Audit Tracking Summary must reference all items included on the Second Year Common Elements Form.

The Performance Audit Tracking Summary is a tool designed to track the progress of the items that the condominium corporation has submitted to Tarion as part of its warranty claim. Tarion will require periodic updates (usually every 90 days) from both the condominium corporation and the builder as to the status of each of the items listed in the Performance Audit Tracking Summary. In the event that the parties are not working to repair the items or otherwise resolve them in a reasonable and diligent manner, Tarion will hold a mandatory meeting with the condominium corporation and the builder which may result in Tarion scheduling a conciliation inspection.

If the Condominium corporation does not submit a Second Year Common Elements Claim Form or Performance Audit to Tarion by the second anniversary of the Registration Date of the Condominium Project, then Tarion will consider no

further claims for second year warranty items (unless the second year warranty item has been previously identified in a First Year Common Elements Claim Form or a Performance Audit and the claim has not been withdrawn).

A condominium corporation may submit as many Second Year Common Elements Forms as required during the second year warranty period.

Years Three to Seven Process: Major Structural Defect (MSD)

At any time after the end of the second year, but no later than the expiry of the seven year anniversary of the Registration Date of the Condominium Project, a condominium corporation can make a Major Structural Defect Common Elements Warranty Claim. To do so, the condominium corporation must submit a Major Structural Defect Common Elements Claim Form to Tarion.

If the condominium corporation does not submit a Major Structural Defect Common Elements Claim Form to Tarion by the end of the seventh year from the Registration Date of the Condominium Project, then Tarion will consider no further claims regarding MSD warranty items.

Step 2: Initial Builder Repair Period

For items listed on a First Year Common Elements Form, the builder has an initial repair period of up to 18 months from the first anniversary of the Registration Date of the Condominium Project to repair or otherwise resolve all warranted items.

For items listed on a Second Year Common Elements Form, the builder has an initial builder repair period of 6 months from the second anniversary of the Registration Date of the Condominium Project to repair or otherwise resolve all warranted items.

Note: The initial builder repair period ends on the same date for First Year Common Elements claims and Second Year Common Elements claim.

Reasonable Access for Repairs

The condominium corporation is required to provide the builder with reasonable access during regular business hours to complete repairs. Appointments should be scheduled at times that are mutually convenient to the builder and the condominium corporation at least 24 hours in advance.

Builders who seek to rely on a refusal of access as a basis for failing to repair warranted items must be able to show that they worked in good faith to arrange mutually convenient dates and times to conduct repairs with the condominium corporation. Builders must make reasonable efforts to accommodate condominium

corporations in scheduling repairs. This will include making at least three attempts to schedule repair work during the repair period with sufficient notice to the condominium corporation. Notice should be in writing and builders should document their efforts to schedule repairs.

Step 3: Condominium Corporation Request for Conciliation

If the builder does not repair or resolve all warranted items listed on either a First Year or Second Year Common Elements Claim Form during the initial builder repair period, the condominium corporation may contact Tarion and request a conciliation by completing the Common Element Request for Conciliation Claim Form at any time within 60 days following the end of the initial builder repair period.

When the condominium corporation requests a conciliation, Tarion will schedule a conciliation inspection appointment with the condominium corporation and notify the builder. The conciliation inspection will be scheduled between the 91st and 150th day from the date that the condominium corporation requests a conciliation.

The condominium corporation and the builder must pay the conciliation fees set out in Appendix B to this Bulletin.

If the condominium corporation does not request a conciliation during the applicable conciliation request period, the condominium corporation will be deemed to have withdrawn all claim items listed on the applicable Common Elements Forms. The condominium corporation may resubmit a Common Elements Claim Form at the applicable times for any items deemed to have been withdrawn if those items are still eligible for warranty at the date of resubmission.

Step 4: Pre-Conciliation Repair Period

The builder has 90 days after the date the condominium corporation requests the conciliation to repair or resolve all of the claim items that are covered by a warranty.

Step 5: Conciliation Process

Unless the condominium corporation requests that the conciliation be cancelled, Tarion will conduct a conciliation inspection at the scheduled date and time. The purpose of a conciliation inspection is to provide Tarion with the opportunity to inspect the items listed on the relevant Common Elements Request for Conciliation Claim Form and make a determination as to whether the items are warranted. In some cases, Tarion will request documentation and information from the condominium corporation and builder to assist in making that determination. Builders are invited to attend conciliation inspections and encouraged to provide assistance as may be required by Tarion.

Following the conciliation, Tarion will issue a Warranty Assessment Report to the condominium corporation and to the builder. The Warranty Assessment Report will set out Tarion's position on all items listed on the Common Elements Form that were not resolved at the time of the conciliation. If there are any items Tarion determines to be covered by warranty under the Act, it will be the builder's responsibility to correct them. In some cases, the Warranty Assessment Report may indicate that further investigation is needed.

If Tarion determines that at least one item in the Warranty Assessment Report is warranted, the conciliation will be a chargeable conciliation unless one of the exceptions set out in Registrar Bulletin 04 - How Chargeability is Determined and Applied is demonstrated.

Conduct at Conciliation or Claim Inspection

All parties at a conciliation or a claim inspection are expected to act in a respectful, courteous and cooperative manner. Builders are expected to follow the direction of Tarion staff and be responsive to requests made by representatives of the condominium corporation. Tarion staff have full discretion to end a conciliation or a claim inspection in the event of disruptive activity by a participant (condominium corporation representative or builder).

To participate in the conciliation or claim inspection process, builders and condominium corporation representatives must abide by all policies issued by Tarion from time to time that relate to the conduct of these inspections, including policies relating to the taking of photographs and video or audio recordings.

Step 6: Post-Conciliation Repair Period

If the Warranty Assessment Report finds any item to be warranted, the builder will be given one final opportunity to repair or resolve the warranted items. The builder will have a maximum of 90 days from the date when Tarion issues the Warranty Assessment Report to resolve all warranted items. For all items Tarion has found to be not warranted in the Warranty Assessment Report, Tarion will issue a Decision Letter to the condominium corporation setting out rights of appeal to the Licence Appeal Tribunal.

If the builder is unable to effect a repair due to a denial of access or due to a disagreement with the condominium corporation as to the method of repair, the builder must notify Tarion in writing of the issue prior to the expiry of the 90-day post-conciliation repair period.

Step 7: Tarion Settles the Claim

If the builder has not completed repairs or otherwise resolved all items covered by warranty within 90 days of the date when Tarion issues the Warranty Assessment Report, Tarion will settle the remaining warranted items directly with the

condominium corporation. This may involve a claim inspection at the Condominium Project, and if so, the builder will be notified in writing of the date and time of the claim inspection. Tarion will make payment out of the guarantee fund directly to the condominium corporation or perform or arrange for the performance or any work and invoice the builder for the amount of the compensation or cost of work plus an administration fee of 15 per cent and applicable taxes.

Example #1 – CE Claims Process for a First Year Claim

This example illustrates the Common Elements claims process that would apply where a condominium corporation submits a First Year Common Elements Form and the Condominium Project registration date is July 1, 2010.

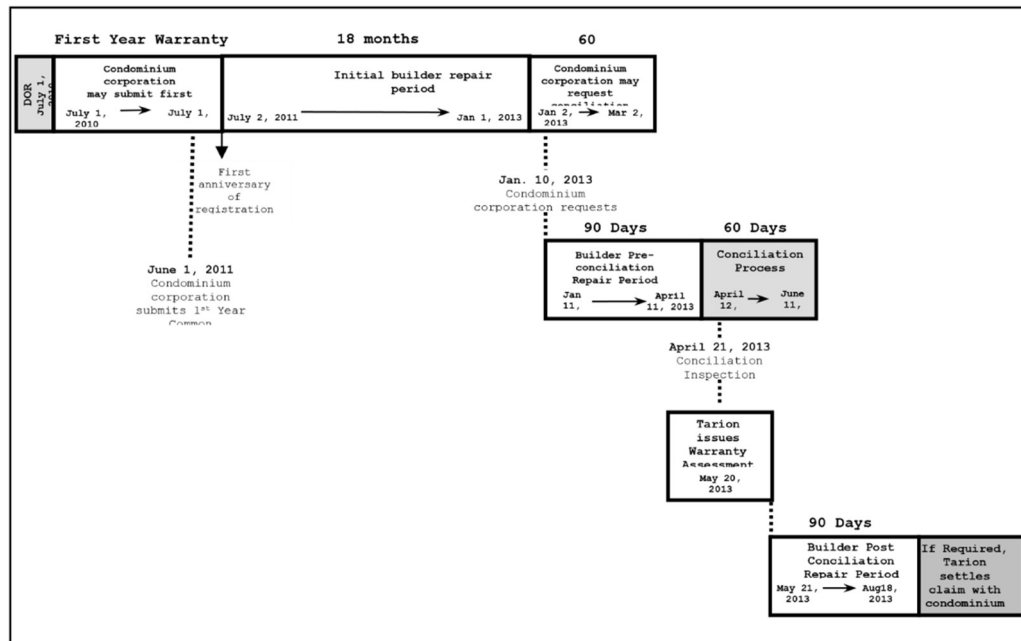

1. The condominium corporation submits a First Year Common Elements Form within the first year warranty period following the Registration Date of the Condominium Project which is the period between July 1, 2010 and July 1, 2011 inclusive. The condominium corporation in this example submits a First Year Common Elements Form on June 1, 2011.
2. The initial builder repair period starts on the first anniversary of the Registration Date of the Condominium Project and lasts for 18 months. In this example, the initial builder repair period ends on January 1, 2013.
3. The condominium corporation may request conciliation at any time during the 60-day period which begins on January 2, 2013. In this example, the condominium corporation requests a Conciliation on January 10, 2013 and Tarion schedules the conciliation inspection on April 21, 2013.

4. The builder has 90 days after the condominium corporation requests a conciliation to resolve any outstanding warranty items submitted on the First Year Common Elements Form before the conciliation inspection takes place. In this example, the builder pre-conciliation repair period is between January 11, 2013 and April 11, 2013.
5. Tarion conducts the conciliation inspection on April 21, 2013 and issues a Warranty Assessment Report on May 20, 2013.
6. The builder has a final post conciliation repair period of 90 days from the date of the Warranty Assessment Report to resolve all warranted items. If the builder fails to resolve all warranted items by the end of the 90-day post conciliation repair period, Tarion will settle those items directly with the condominium corporation.

Example #2 – CE Claims Process for a Second Year Claim

This example illustrates the Common Elements claims process that would apply where a condominium corporation submits a Second Year Common Elements Form and the Condominium Project registration date is July 1, 2010.

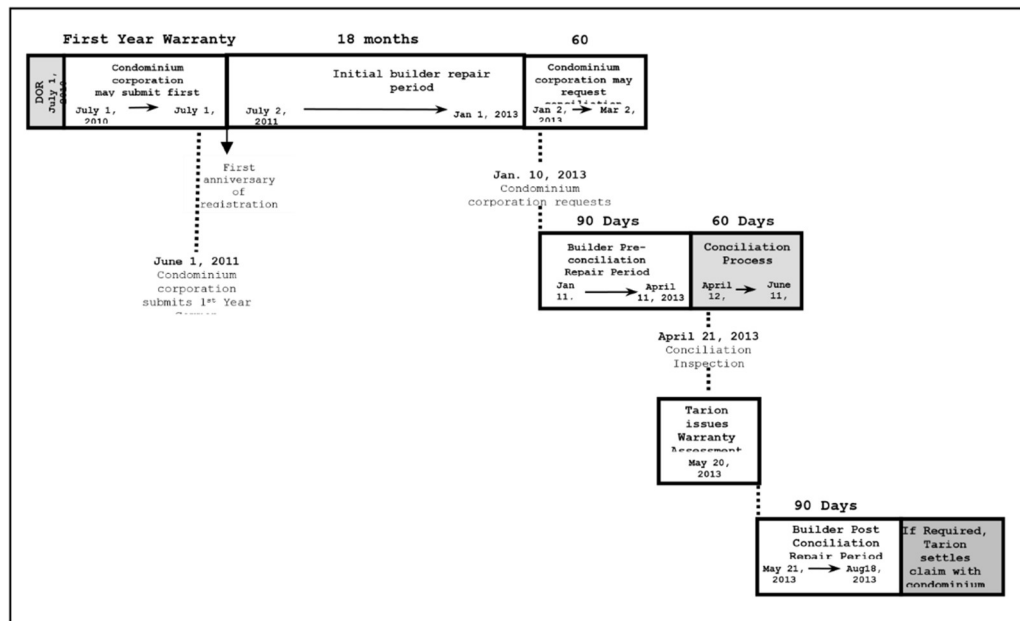

1. The builder has a final post conciliation repair period of 90 days from the date of the Warranty Assessment Report to resolve all warranted items. If the builder fails to resolve all warranted items by the end of the 90-day post conciliation repair period, Tarion will settle those items directly with the condominium corporation.

Builder Arbitration Forum

A builder who disagrees with Tarion's determination of warrantability or chargeability in a Warranty Assessment Report may be eligible to request an arbitration under the Builder Arbitration Forum. An arbitration request may only be made by registered builders who attended the conciliation inspection and must be made within 28 days of receiving the Warranty Assessment Report. For full eligibility requirements and other information, please refer to Registrar Bulletin No. 08 (formerly Builder Bulletin 41: Builder Arbitration Forum).

Registrar

"Peter Balasubramanian"

Appendix A: Exceptions to the CE Claims Process

The CE Claims Process and timelines apply to all Common Elements warranty claims except those set out in this section. Under the Exceptions, the CE Claims Process will be adjusted for the following situations.

1. Emergencies

An emergency warranty situation is any situation that occurs within the warranty period and involves a warranted item that if not attended to immediately, in the opinion of Tarion, would likely: result in substantial damage to the Common Elements; represent a substantial risk to the health and safety of any occupants of the Condominium Project; or result in one or more homes in the Condominium Project being uninhabitable.

An emergency include(s) the following situations as they relate to one or more homes:

- Complete loss of heat between September 15 and May 15;
- Complete loss of air conditioning between May 15 and September 15;
- Gas leak;
- Complete loss of electricity;
- Complete loss of water;
- Complete stoppage of sewage disposal;

An emergency also include(s) the following situations:

- Plumbing leak that requires the entire water supply to be shut off;
- Major collapse of any part of the Condominium Project exterior or interior structure;
- Water penetration through the walls or ceilings of Common Elements affecting a finished/occupied Common Element area or a unit;

- A pool of standing water upon or within the Common Elements, or any portion thereof; and could impact critical use or be considered a health & safety issue;
- Loss of use of all elevators;
- Presence of unacceptable levels of hazardous substances – such as radon and mould – inside the Condominium Project due to an issue with a Common Element.

Damage that is excluded from warranty (for example, municipal or utility service failures or 'acts of God'), would therefore not be an "emergency" warranty situation.

Emergency Procedure

1. A condominium corporation that believes there is an emergency situation should contact the builder first. The condominium corporation should follow the builder's instructions in attempting to handle the emergency situation.
2. The builder is permitted up to 24 hours to resolve the emergency and to ensure that the situation has been made safe and secure and to prevent any further damage from occurring. Full repair of the defect in accordance with the builder's warranty obligations may take longer to complete once the initial emergency has been dealt with. Builders are required to complete the full repair (including repairing any damage to builder installed materials) in accordance with their warranty obligations as soon as possible and no later than 30 days from the date that the condominium corporation reported the emergency.
3. If the builder cannot be reached within 24 hours or if the builder has been contacted but has not resolved the emergency within 24 hours, the condominium corporation may contact Tarion for further direction. Tarion will determine (usually by phone) whether there is an emergency situation or if the item should be added to the condominium corporations next Statutory Common Elements Form. If Tarion concludes that there is a warranted emergency situation, Tarion will first try to contact the builder. If Tarion is unable to contact the builder or the builder is unwilling or unable to resolve the warranted emergency item, Tarion will instruct the condominium corporation to perform or arrange for the performance of repairs necessary to correct the emergency, i.e., any repairs necessary to make the identified common elements safe and secure and to prevent any further damage in the near future.
4. If the condominium corporation is unable to contact the builder and Tarion and the condominium corporation believes there is a warranted emergency, the condominium corporation may, without jeopardizing its warranty rights, perform or arrange for the performance of repairs necessary to correct the warranted emergency only. Tarion will only reimburse the condominium corporation for the cost of repairing warranted items.
5. If the condominium corporation has arranged to have the emergency repairs done and wishes to be reimbursed, the condominium corporation is required to obtain a Common Elements Emergency Form (available from Tarion by calling 1-877-982-7466 or from the Tarion website), and to submit to Tarion and the builder the completed Emergency Form along with all required supporting documents (i.e., receipts, photographs of the damage and repair if available).
6. Within 10 days of receipt of the completed Emergency Form, Tarion will contact the builder to determine whether the builder has reimbursed the condominium corporation. If the builder has not reimbursed the

condominium corporation for all expenses incurred to correct the emergency, Tarion will conduct a conciliation and issue a Warranty Assessment Report to the condominium corporation and the builder. If Tarion identifies any emergency item as warranted in the Warranty Assessment Report, the conciliation will be considered chargeable.

7. Tarion will notify the builder that the builder has 30 days to reimburse the condominium corporation for their reasonable costs associated with the warranted repairs undertaken and to complete repairs to damaged builder installed materials, as documented in the Emergency Form and confirmed by Tarion in the Warranty Assessment Report.
8. If the builder fails to reimburse the condominium corporation, Tarion will settle directly with the condominium corporation and make payment to the condominium corporation out of the guarantee fund. The builder will be invoiced for the amount of the compensation paid plus an administration fee of 15 per cent and any applicable taxes.

2. Seasonal Items

If any warranted item listed on a Statutory Warranty Form submitted to Tarion involve the exterior of the Common Elements which cannot be repaired effectively within the normal CE Claims process due to weather constraints, Tarion in its sole discretion may extend or abridge the CE Claims process timelines.

3. Industry/Regional Extraordinary Situations

Industry/Regional Extraordinary Situations may require an extension of the applicable builder repair period for a part of the construction industry, a region, or the entire province. Examples include:

- An irregular (i.e., not ongoing or “normal”) labour or trade shortage;
- An irregular (i.e., not ongoing or “normal”) shortage of work material;
- Strikes or other serious labour disruptions; and
- Severe weather or other ‘acts of God’.

Procedure for Industry/Regional Extraordinary Situations

The Procedure for Industry/Regional Extraordinary Situations is as follows:

1. A potential Industry/Regional Extraordinary Situation may be brought to the attention of Tarion by a written notice from a builder or recognized new home building association;
2. Tarion will thoroughly review the information, and may require additional documentation to assess the situation;
3. If Tarion confirms that an Industry/Regional Extraordinary Situation exists or is about to occur, Tarion will issue a written Warranty Alert to all builders affected. The Alert will describe the nature of the event; which regions,

industries, or types of warranties are affected; and in what circumstances the permitted extension will apply to the relevant builder repair periods; and

4. A builder who is affected by the Industry/Regional Extraordinary Situation and wishes to apply the extended builder repair period provided in the Warranty Alert is required to provide written notice to the affected condominium corporation as soon as possible. The notice must be delivered before the expiry of the applicable builder repair periods, and no later than 10 days from receipt of the Alert. The notice must include an explanation of why the extension is required for the particular condominium corporation and the number of days that the builder repair period has been extended due to the Alert. The standard builder repair periods in the CE Claims Process will continue to apply to builders who do not provide this notice to their condominium corporations.

Appendix B: Conciliation Fees

The fee payable by a condominium corporation as the owner of Common Elements for a conciliation	\$1,000
The fee payable by the vendor of Common Elements for a conciliation	\$3,000